

The place of experiment in the mind-brain sciences

A. K. MOSCHOVAKIS

*Institute of Applied and Computational Mathematics, FO.R.T.H. and
Dept. Basic Sciences, Faculty of Medicine, University of Crete*

ABSTRACT

The goal of the Neurosciences is to provide an account of how the brain works. There are several experimental approaches which provide data on which to build such an account: 1) Psychophysical experiments provide quantitative descriptions of psychological processes (e.g., movement, perception, learning and memory, emotion, etc.). 2) Lesion, ablation, stimulation studies and functional brain imaging studies provide a gross estimate of brain regions likely to be entrusted with some of these processes. 3) Extracellular recording experiments in alert behaving animals provide information about signal traffic in the brain. 4) Anatomical experiments provide information about connections in the brain. 5) Computational models offer a global, coherent account of the data and guide future research through a boot strapping process. It is argued that this broad scientific program has the conceptual resources to reduce Psychology to the Neurosciences. It is also argued that such a reduction (conceived in both epistemological and ontological terms) and the deterministic universe it presupposes poses no threat either to Psychology or to our sense of self.

Key words: Epistemology, neurosciences, reductionism

This report addresses a very simple-minded question: What is it that we need to know to understand how the brain works? Clearly, the brain's job is to generate mental events, be they observable (such as movement) or hidden (such as perception, imagination, emotion, etc.). Here, I will primarily deal with movement because this is my field of expertise, but I harbor no doubts that similar arguments hold for other psychological processes.

There are lots of different movements (e.g., smooth pursuit eye movements, head movements, reaching arm movements, prehension grip movements, etc.) controlled by the brain and, in general, each one of these is controlled by a different part of the brain. Let us assume that one of these has been singled out for

a careful and hopefully quantitative study. Figure 1 provides an example of the first step in such a study; it illustrates records of the instantaneous position of the eyes (sampled at 500 Hz). Note the fast changes of the traces in Figure 1. These are rapid movements, called saccades, which we execute at a rate of 3 per every second of our waking life to explore the world. Upon a closer look at data such as these, certain regularities emerge. For example, the amount of roll of the eyes is specified by their horizontal and vertical position. This is a fact that is known for more than a century, ever since Donders enunciated it in the form of the law that bears his name. Pursuing this line of research to finer detail, the amplitudes of saccades, their peak velocities, their durations, etc., are measured, and the existence of further

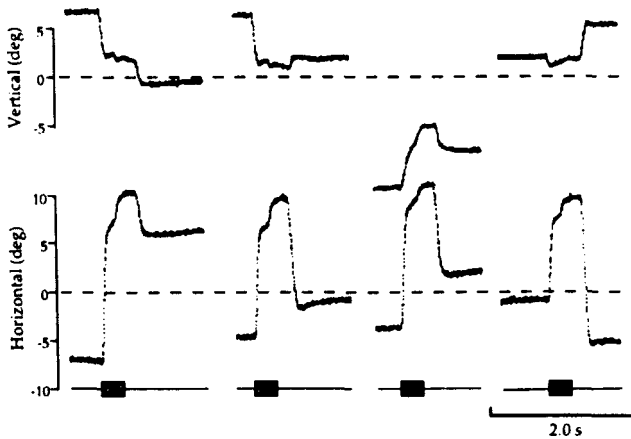

Figure 1

Examples of movements evoked in response to the electrical stimulation of the left superior colliculus (70 pulses at $3 \times T$) in the cat (modified from Grantyn, A. A., Dalezios, Y., Kitama, T., & Moschovakis, A. K. Neuronal mechanisms of two-dimensional orienting movements in the cat. I. A quantitative study of saccades and slow drifts produced in response to the electrical stimulation of the superior colliculus. *Brain Research Bulletin*, 41, 65-82, 1996, with permission). Boxes indicate the onset and duration of stimulus trains. Dashed lines indicate zero horizontal and vertical eye position.

regularities emerges. Figure 2a, illustrates the relationship (known as «main sequence») between the horizontal size of saccades (about 2000 of them are shown in this figure) and their peak velocity. Note that the data falls along a straight line. A similar relationship holds between the size of the vertical components of saccades and the vertical peak velocity of the eyes (Figure 2b). The slope of the main sequence curve differs for different species. The one illustrated in Figure 2 is from work in the cat that I recently did together with Alexej Grantyn and our colleagues (Grantyn, Dalezios, Kitama, & Moschovakis, 1996). Humans have steeper slopes and monkeys even steeper, while rabbits have shallower and the goldfish is somewhere in between. In case you are worried about the future of psychology, you can be assured that statements such as these are here to stay (they are the venerated laws of psychophysics). As such the laws of psychophysics are the spearhead of our efforts to understand how the

brain works; it is our task to explain how brain processes give rise to the phenomena that these laws describe.

We are unlikely to accomplish this goal unless we look inside the brain. Well, the brain is big and complex, so where do we look? There is no reason why one should not start with classical approaches such as lesion and stimulation experiments. These techniques date from the time of Flourens in the previous century, and in his hands they proved disastrous. But, in our days, there are better ways to carry them out. Figure 3 illustrates an example from work in the monkey, undertaken by Albert Fuchs and his colleagues in Seattle (Robinson, Straube, & Fuchs, 1993). Normal monkeys have no difficulty in moving their eyes upon request (and for a reward) ten degrees to the right or ten degrees to the left, ten degrees down or ten degrees up (Figure 3), and then back to where they started from. Now, it is possible to lower a very small canula inside the brain, till it reaches the left

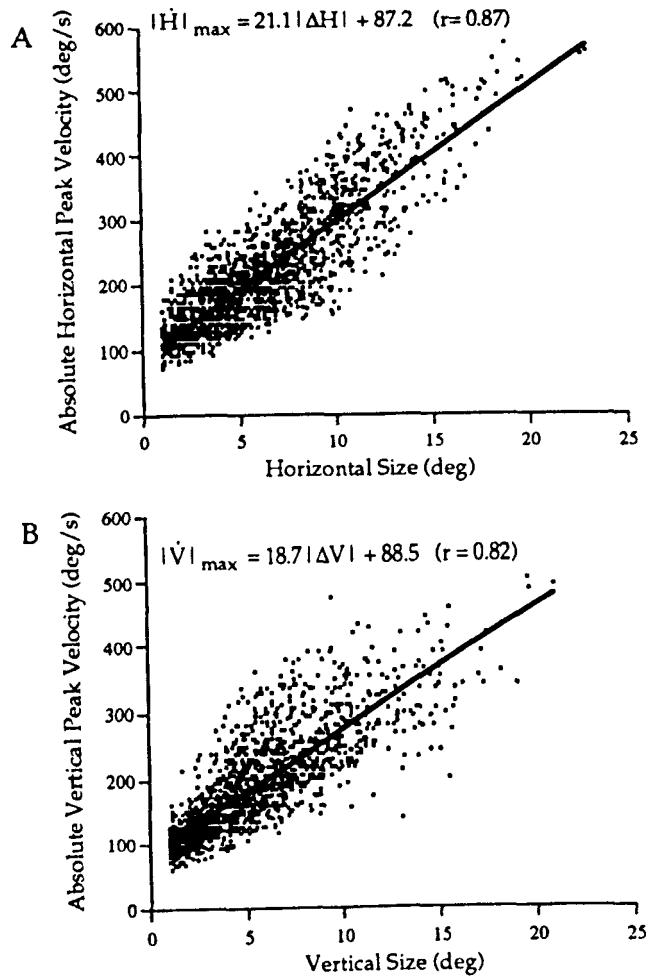

Figure 2

Plots of absolute horizontal (A) and vertical (B) peak eye velocity ($|\dot{H}|_{\max}$ and $|\dot{V}|_{\max}$) of saccades vs. absolute size of horizontal ($|\Delta H|$) and vertical ($|\Delta V|$) saccadic components, respectively (reproduced from Grantyn, A. A., Dalezios, Y., Kitama, T., & Moschovakis, A. K. Neuronal mechanisms of two-dimensional orienting movements in the cat. I. A quantitative study of saccades and slow drifts produced in response to the electrical stimulation of the superior colliculus. *Brain Research Bulletin*, 41, 65-82, 1996, with permission). Each point represents an individual saccade. Solid lines obey the displayed equations and are the linear regression lines through the data.

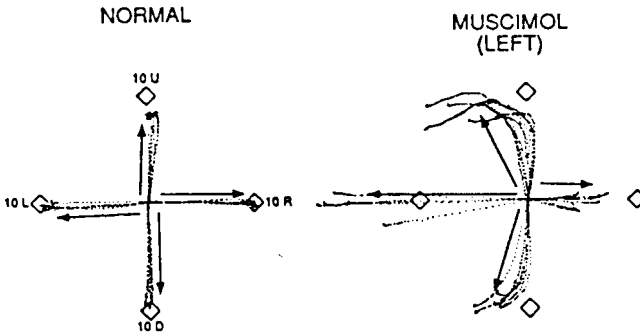

Figure 3

Trajectories of centrifugal saccades to 10 deg target displacements (diamonds) before (left) and after (right) muscimol injections into the left fastigial nucleus (modified from Robinson, F. R., Straube, A., & Fuchs, A. F. Role of the caudal fastigial nucleus in saccade generation. II. Effects of muscimol inactivation. *Journal of Neurophysiology*, 70, 1741-1758, 1993, with permission).

fastigial nucleus (one of the deep cerebellar nuclei), there to inject minute amounts of a substance (the GABA agonist muscimol). Following which, lo and behold, the ipsiversive movements (leftward) become hypermetric (Figure 3), the contraversive ones (rightward) become hypometric, and vertical ones veer towards the side of the lesion. In these symptoms, our colleagues in the neurology clinics will no doubt recognise Wallenberg's syndrome. It is remarkable that lowering a canula inside the brain and injecting some chemical suffices to reproduce a human syndrome.

Let us now turn to the electrical stimulation technique. Instead of a canula, it is a wire passing electrical current that is now lowered in the brain. Depending on where in the brain the electrode ends, various movements (and sensations, memories, etc.) are evoked. When the stimulating electrode finds itself in a nucleus that is called superior colliculus the movement produced is a saccade (Figure 1). The metrics of the movement (its amplitude and direction) depend on the location of the electrode in the nucleus. If a bigger movement or one in a different direction is desired, one need only remove the electrode and lower it in a different place inside the same

nucleus. The movements evoked in response to electrical stimulation are so very stereotypical, that if the stimulus is left on for a long period of time a second movement follows the first (Figure 1) then a third, etc. (a so-called staircase of saccades). Parenthetically, the use of electrical stimulation and selective (often reversible) lesion allows one to satisfy «sufficiency and necessity criteria» in that for a region to be causally relevant for a behavior, its activation must evoke the behavior (sufficiency) while the behavior is blocked when the region is deactivated (necessity).

Nowadays, it is possible to literally see the engagement of a brain area in ongoing behavior. To this end, a hole is opened in the skull, the cortex is fed with a substance that lights up in proportion to the level of activity of neurons, and the lens of a video camera is placed on top of the hole. Depending on the stimuli that the animal is presented with and the intensity of discharge of the cells they contain, different regions of the cortex emit a stronger or weaker optical signal. Figure 4 illustrates results that Blasdel (1992) obtained with this technique from the primate primary visual cortex (V1) in response to visual stimuli of different orientations (the substance

The
Journal
of **Neuroscience**

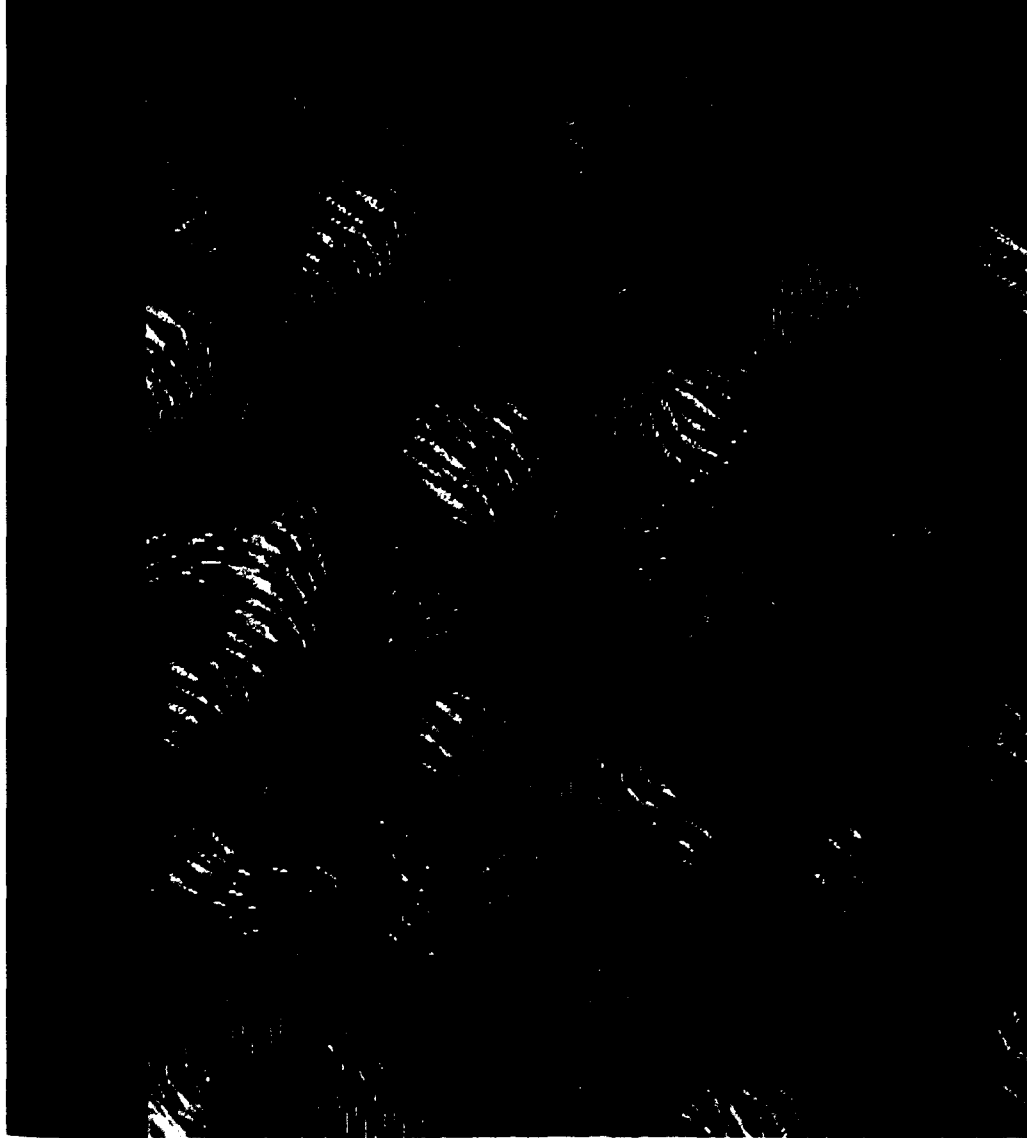

Figure 4

Orientation columns of the primary visual cortex of the rhesus monkey visualized with the help of voltage sensitive dyes (reproduced from Blasdel, G. G. Orientation selectivity, preference and continuity in monkey striate cortex. *Journal of Neuroscience*, 12, 3139-3161, 1992, with permission).
White directed segments indicate the orientation preference of the underlying patch.

used here was a voltage sensitive dye). As shown here, the subregions of V1 activated by horizontal stimuli (green) differ from those activated by vertical stimuli (red) and these again differ from those activated by stimuli of other orientations.

Techniques such as these offer us an outline of the lay of the land (roughly, a list of regions likely to engage in a certain behavior). To obtain a description of the working brain in terms of networks of interacting neurons three additional crucial pieces of information are needed: 1) Who's talking to whom, 2) What is it that is being said, 3) How do the messages change as they move from one place to another. I will start with the third issue, but I'll only touch upon it obliquely because a step by step account demands a lot of space. Figure 5 illustrates relevant data which I obtained from a «fictitiously» walking cat together

with Gerry Sholomenko and Bob Burke (Moschovakis, Sholomenko, & Burke, 1991b). The top four traces illustrate activity encountered in several hind-limb muscle nerves. The top two innervate typical extensors (MG and FHL), i.e., muscles engaged during the stance phase of walking (when the leg is firmly planted on the ground) while the bottom one innervates a typical flexor (TA), i.e., a muscle activated during the transport phase of walking (when the same leg is lifted and moved forward). The third trace is from the nerve of a bi-functional muscle (FDL) which pushes all fingers inward so that the size of the foot is decreased and the leg can be transported with relative ease. Notice the typical alternating pattern of activation of extensors (circles above the nerve traces) then flexors (triangles) then again extensors, etc., which accompanies the

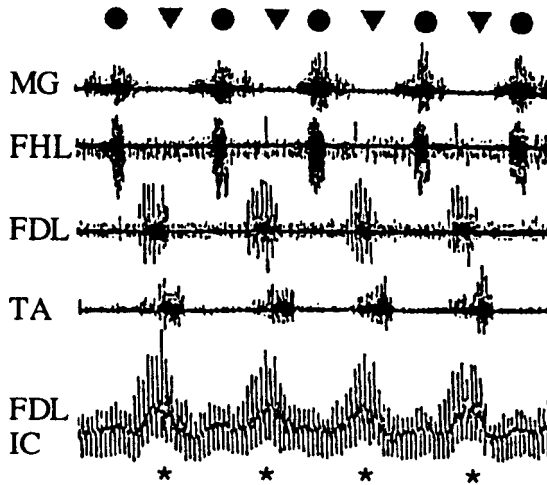

Figure 5

Intracellular records (FDL-IC) obtained from a flexor digitorum longus (FDL) motoneuron in a low spinal (T13) decerebrate cat during stimulation of the superficial peroneal nerve (2xT, approximately 10 Hz) and fictitious stepping induced with Nialamide and L-DOPA (modified from Moschovakis, A. K., Sholomenko, G. N., & Burke, R. E. Differential control of short latency cutaneous excitation in cat FDL motoneurons during fictive locomotion. *Experimental Brain Research*, 83, 489-501, 1991, with permission). Abbreviations: FHL, flexor hallucis longus; MG, medial gastrocnemius; TA, tibialis anterior. Thin vertical lines riding under the intracellular record indicate voltage transients evoked in response to intracellular pulses of constant current to measure the input resistance of the cell.

movement of the limb as it alternately flexes and extends during walking. The bottom trace is an intracellular record of the voltage across the membrane of an FDL motoneuron. Motoneurons are the big cells that tell our muscles what to do. Notice the periodic depolarization (asterisks right underneath the intracellular voltage trace) of the motoneuron in phase with activity in the FDL nerve trace. Imagine now that while walking you come upon a stone. Instead of jumping over it or tripping over it you lift your leg higher to go over the stone without disrupting your normal walking pattern. To some extent this is done because you can predict the height of the stone and thus know how much higher you must lift your leg. Suppose, nevertheless that you made the wrong prediction and your foot hits the stone. Again, chances are you will not trip over it. The reason is that certain cutaneous stimuli are given a window of opportunity which coincides with the transport phase of walking. If they occur within this window, stimuli from the leg dorsum can excite a lot more the motoneurons that talk to the muscles that lift the leg (and curl the toes). The increased synaptic response of a motoneuron to cutaneous stimuli during the transport phase is illustrated in Figure 5 (it is indicated by the length of the lines that ride on top of the intracellular voltage trace). Evidently, the constant cutaneous signal that enters the spinal cord is modified (by ventral horn interneurons) during particular phases of walking.

To explain how we go about securing the second crucial piece of information (who talks to whom) I must ask you to consider Figure 6, which is a schematic diagram of the horizontal portion of the saccadic system. It is made up of several cell classes, which differ in terms of the nuclei they live in, the reasons they fire for and the ways they are connected to each other (twelve classes of connections are shown here, as arrows numbered consecutively). Parenthetically, the network of Figure 6 is a real neural network, meaning a network of real neurons located inside real brains. It has nothing to do with what neural-net people call «neural nets». A more appropriate term for the latter would be «parallel distributed processing circuits». There are several

differences between real neural networks and parallel distributed processing circuits. The most obvious one concerns connectedness. Whereas parallel distributed processing networks are richly connected (in the sense that everybody talks to almost everybody else), real neural networks are sparsely connected. The connectedness of the nets that comprise the saccadic system is equal to about ten per cent of what it would have been had the nets been fully connected.

How does one know that a specific type of cell, say the IBN of Figure 6, talks to its counterpart in the opposite side of the brain, or that this connection (#5 of Figure 6) is an inhibitory one? Well, there are several ways to find out. In general, to think that neurons of type a_1 (located within nucleus A) establish synaptic contacts with cells of type b_1 (located within nucleus B), the following facts must be documented: 1) Nucleus A projects to nucleus B ($A \rightarrow B$). 2) Nucleus A projects to cells of type b_1 ($A \rightarrow b_1$). 3) Cells of type a_1 project to nucleus B ($a_1 \rightarrow B$). 4) Cells of type a_1 project to cells of type b_1 ($a_1 \rightarrow b_1$). These criteria are arranged in order of stringency, in the sense that statements of the form $a_1 \rightarrow b_1$ imply the truth of statements $A \rightarrow B$, but not the other way around. As shown in Figure 6, the evidence that supports the existence of connections between different elements of the horizontal saccadic system is voluminous and is best described in terms of families of evidence (e.g., of the $A \rightarrow B$ type or of the $a_1 \rightarrow b_1$ type). In Fig. 6, different families of evidence occupy different columns (to be found in the following sources: α , Carpenter, McMasters, & Hanna, 1963; β , Carpenter & McMasters, 1963; γ , Goebel, Komatsuzaki, Bender, & Cohen, 1971; δ , Graybiel & Hartweg, 1974; ϵ , Büttner-Ennever & Henn, 1976; σ , Highstein, Maekawa, Steinacker, & Cohen, 1976; ζ , Graybiel, 1977; η , Hikosaka & Kawakami, 1977; θ , Maciewicz, Eagen, Kaneko, & Highstein, 1977; ι , Spencer & Sterling, 1977; $\iota\alpha$, Hikosaka, Igusa, Nakao, & Shimazu, 1978; $\iota\beta$, Highstein & Baker, 1978; $\iota\gamma$, Steiger & Büttner-Ennever, 1978; $\iota\delta$, Gacek, 1979; $\iota\epsilon$, Nakao & Sasaki, 1980; $\iota\sigma$, Grantyn, Baker, & Grantyn, 1980; $\iota\zeta$, Igusa, Sasaki, & Shimazu, 1980; $\iota\eta$,

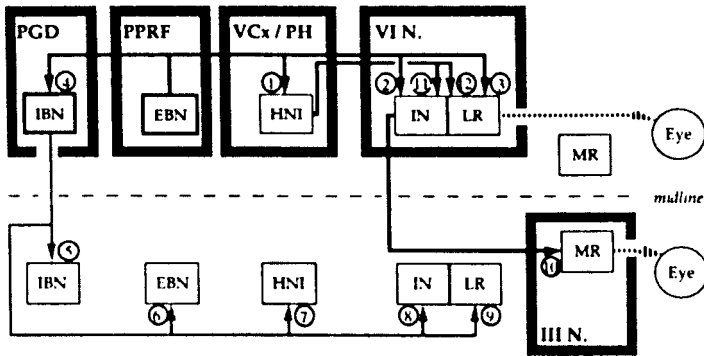

	A→B	A→b ₁	a ₁ →B	a ₁ →b ₁
1)	ε, ζ, ιζ, κδ, κε, κς		λα	
2)	γ, ε, ζ, ιζ, κθ, λγ	ς	ιζ, ιθ, λα	
3)	γ, ε, ζ, ιζ, κθ, λγ	ς, ια	ιζ, ιθ, λα	
4)	ς	ιζ	ιθ, λα	
5)			κγ, λβ	
6)	κ, κη		λβ	
7)	ς, κς		ιη, κγ, λβ	ιη
8)	ς, θ, κθ, λβ		η, ια, ιη, κγ, λβ	ιη
9)	ς, θ, κθ, λβ, λδ	η, κς, λδ	η, ια, ιη, κγ, λβ	ια, ιη
10)	α, β, δ, ι, ιγ, λ	ιβ, ιε, κβ	κα, λ	
11)	ιδ, ζ, θ, κς		λε	
12)	ιδ, ζ, θ, κς		λε	λε

Figure 6

Schematic illustration of the output connections of excitatory burst neurons (EBN) and inhibitory burst neurons (IBN) of the horizontal saccadic system (modified from Moschovakis, A. K., Scudder, C. A., & Highstein, S. M. The microscopic anatomy and physiology of the mammalian saccadic system.

Progress in Neurobiology, 50, 133-254, 1996, with permission). Solid lines indicate excitatory connections, stippled lines indicate inhibitory connections, striped lines indicate the pattern of motoneuronal innervation of extraocular muscles, and the dashed line indicates the midline. Nuclei indicated by light stippled boxes. To avoid clutter, symmetric connections are not drawn.

Abbreviations: III N., oculomotor nucleus; IV N., abducens nucleus; HNI, horizontal neural integrator; IN, abducens internuclear neurons; PGD, nucleus paragigantocellularis dorsalis; PPRF, paramedian pontine reticular formation; VCx/PH, vestibular complex and prepositus hypoglossi.

Hikosaka, Igusa, & Imai, 1980; ιθ, Sasaki & Shimazu, 1981; κ, Stanton & Greene, 1981; κα, Highstein, Karabelas, Baker, & McCrea, 1982; κβ, Dememes & Raymond, 1982; κγ, Yoshida, McCrea, Berthoz, & Vidal, 1982; κδ, Langer & Kaneko, 1983; κε, Magnin, Courjon, & Flandrin, 1983; κστ, McCrea & Baker, 1985; κζ, Porter, Guthrie, & Sparks, 1985; κη, Schnyder, Reisine, Hepp, & Henn, 1985; κθ, Langer, Kaneko,

Scudder, & Fuchs, 1986; λ, McCrea, Strassman, & Highstein, 1986; λα, Strassman, Highstein, & McCrea, 1986a; λβ, Strassman, Highstein, & McCrea, 1986b; λγ, Sirkin & Feng, 1987; λδ, Scudder, Fuchs, & Langer, 1988; λε, Escudero, de la Cruz, & Delgado-Garcia, 1992). How does one obtain evidence of one sort or another concerning a class of connections? One of the methods involves lowering a micro-electrode

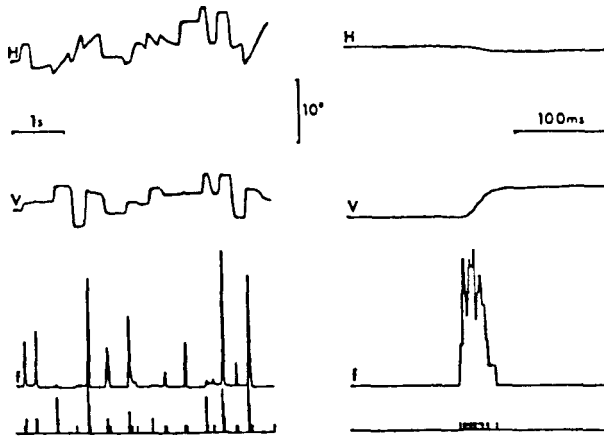

Figure 7

Two panels, at different sweep speeds, which illustrate the discharge pattern of an upward medium lead burst neuron for saccades of different directions (reproduced from Moschovakis, A. K., Scudder, C. A., & Highstein, S. M. Structure of the primate burst generator. I. Medium-lead burst neurons with upward on-directions. *Journal of Neurophysiology*, 65, 203-217, 1991, with permission). Calibration bars of 1 s and 100 ms apply only to the left and right panels, respectively. Calibration bar of 10 deg applies to all eye position traces.

inside the brain of an alert animal, till it is lodged inside a neuron of interest. In this manner, the cell's discharge pattern can be studied in relation to external stimuli or behavioral acts. Figure 7 provides an example from a study that I did a few years ago with Charlie Scudder and Steve Highstein concerning cells that fire for vertical saccades (Moschovakis, Scudder, & Highstein, 1991a). The top trace in each panel is the horizontal instantaneous position of the eyes (H), the second is the vertical instantaneous position of the eyes (V), then comes the instantaneous firing rate of the cell (f) and the bottom trace is the actual spike-train. As shown here, every time the eyes move up the cell gives a burst of activity. Analysis of spike trains in relation to external physical variables (in our case saccade kinematic and dynamic variables) allows one to infer the parameters of the movement (or the stimulus) that are encoded by neurons. In this manner, we obtain information about signals trafficking inside the brain (the «what is it that is being said» crucial

piece of information). Furthermore, the same electrode used to obtain records of neuronal activity can be loaded with a substance which is then dumped inside the cell. Following histochemistry, neuronal processes containing the substance can be visualized under a microscope, thus elucidating the cell's location, the branching pattern of its axon, as well as its synaptic terminations in several brain areas (Figure 8). The point of interest in the photomicrograph of Figure 8, is the varicosities (arrows); each one of them is known to correspond to a synapse. Clearly, this evidence is of the $a_1 \rightarrow B$ type, where a_1 is the class of upward (a) or downward (b) medium lead burst neurons and B is the interstitial nucleus of Cajal (a) or the nucleus of the fourth cranial nerve (b; parenthetically this connection is the vertical counterpart of #12 in Fig. 6).

So far we have visited examples of techniques that give us information about signals transmitted from one place to another inside the brain, their

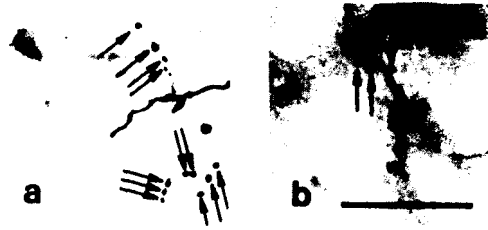

Figure 8

Photomicrographic details of terminal arborizations from a primate upward medium lead burst neuron in the interstitial nucleus of Cajal (a) and from a primate downward medium lead burst neuron in the trochlear nucleus (b). Both neurons were intraaxonally injected with horseradish peroxidase (reproduced from Moschovakis, A. K. Neural network simulations of the primate oculomotor system. II. Frames of reference. *Brain Research Bulletin*, 40, 337-345, 1996, with permission). Calibration bar is 50 mm in (a) and 40 mm in (b).

way-stations and the manner in which they are modified. Information such as this can acquire massive proportions. To give you an idea of what present day brain circuits look like, Figure 9 reproduces the mammalian circuit that controls saccades. The obvious thing to notice is the circuit's extreme complexity; it looks like the printed integrated circuit of a hi-fi amplifier. This should not come as a surprise. Firstly, the circuit contains four bi-directional saccade generators, one for left and one for right, one for up and one for down, and each one of these is endowed with its own local feedback loop. Secondly, saccade generators of different directions are coupled via an omnipause loop. Finally, there are higher order trans-collicular (center), trans-cerebellar (right), and trans-cortical (left) loops which occupy the top part of this figure. Clearly, circuits such as this and the processes they underlie can not be understood without detailed study with the help of sophisticated computational methods. To illustrate the effort that goes into the construction and study of a neural network model I will use a simpler one, from a simpler animal. Figure 10A illustrates a network which controls the escape swimming of the mollusk *Tritonia diomedea* and was elucidated by Peter Getting (Getting, 1983; Getting, 1989; Getting & Dekin, 1985). Not unlike mammalian circuits, it involves multiple levels of

feedforward and feedback pathways embedded in complex arrays of connections and cells. Furthermore, depending on the state of the cerebral cell 2 (C2), the network is functionally reconfigured into one that controls reflexive withdrawal (Figure 10B) or one that gives rise to an alternating swimming pattern (Figure 10C). In the former, the animal is not swimming, the C2 cell is silent, the network is dominated by inhibitory interactions and each interneuron separately routes afferent input to motoneurons thus mediating reflexive withdrawals. In the latter, the C2 fires in bursts, inhibits the I cell, and due to the mutual excitation among the dorsal swim interneurons (DSI) these cells dominate the performance of the network which settles in a sequence of alternating bursts between the DSI and the ventral swim interneurons (VSI). Making use of information about how the cells are connected to each other and the strength, kinetics and sign of their synaptic interactions Getting was able to build a computer model of this network which reproduced the alternating pattern between the DSI and the VSI (Figure 10, inset) that is observed in real animals (Figure 11). With one caveat; the strength of the VSI to DSI connection had to be increased above its known physiological strength. This result suggested the existence of additional VSI cells that had eluded

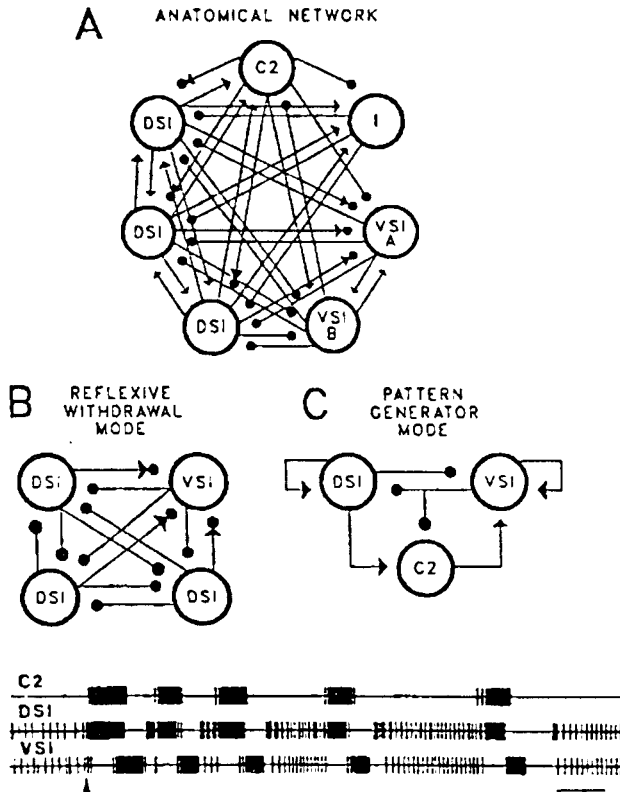

Figure 10

Diagrammatic illustration of the network that controls escape swimming in *Tritonia* (reproduced from Getting, P. A. Emerging principles governing the operation of neural networks. *Annual Reviews of Neuroscience*, 12, 185-204, 1989, with permission). A. Complete network. B. Network configuration when the *Tritonia* is inactive. C. The network as reconfigured to sustain swimming. Excitatory synapses are indicated by arrows and inhibitory synapses by solid circles. Abbreviations: C2, cerebral cell 2; DSI, dorsal swim interneuron; VSI, ventral swim interneuron. Bottom: Simulated swim pattern

(reproduced from Getting, P. A. Mechanisms of pattern generation underlying swimming in *Tritonia*. II. Network reconstruction. *Journal of Neurophysiology*, 49, 1017-1035, 1983, with permission). An extrinsic synaptic input to the DSI was simulated at 10 Hz for 1 s at the arrow to produce a prolonged ramp depolarization of the DSI. Each vertical bar represents the time of firing for each of the three interneuron types. Horizontal calibration: 5 s.

It might be argued that although eminently successful in invertebrates, this line of research need not prove fruitful for the much more complex mammalian brains. To demonstrate that the pessimism of this position is unwarranted, let us

return to the saccadic circuit of Figure 9. To see how this circuit works, we must zoom into one of the saccadic generator local feedback loops (Figure 12). This is a model that I proposed a little while ago (Moschovakis, 1994) and is known as

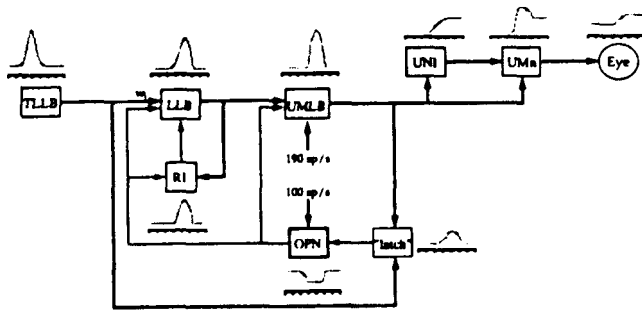

Figure 11

Simultaneous intracellular recordings from the C2, DSI and two VSI cells (VSI-A and VSI-B) during swim activity of the *Tritonia* initiated by electrical stimulation (bar below VSI-B trace; reproduced from Getting, P. A., & Dekin, M. S. Mechanisms of pattern generation underlying swimming in *Tritonia*. IV. Gating of central pattern generator. *Journal of Neurophysiology*, 53, 466-480, 1985, with permission). Dashed lines, resting potential. Calibrations: vertical 50 mV for c2, DSI and VSI-B; 25 mV for VSI-A; time scale, 5 s.

the MSH model. In general, the activation functions of elements in such circuits (illustrated above or below the element they concern) are calculated from expressions of the form,

$$A_n = \sum_{i=0}^m I_{(n-1)_i} W_i$$

where A_n is the instantaneous discharge at time n , of a unit receiving input (I) from m units, and W_i is the strength of the connection between unit i and the unit of interest. Let us take one of these activation functions, namely the one associated with motoneurons (shown above the UMn element of Figure 12). How does it compare with the discharge pattern of a vertical motoneuron? The answer is shown in Fig. 13. As shown here,

Figure 12

The MSH model of the saccadic system (reproduced from Moschovakis, A. K., Scudder, C. A., & Highstein, S. M. The microscopic anatomy and physiology of the mammalian saccadic system. *Progress in Neurobiology*, 50, 133-254, 1996, with permission). Abbreviations: ΔE , desired eye displacement; RI, resettable integrator; LLB, long lead burst neuron; OPN, omnipause neuron; TLLB, tectal long lead burst neuron; UMLB, upward medium lead burst neuron; UNI, upward neural integrator; UMn, upward motoneuron.

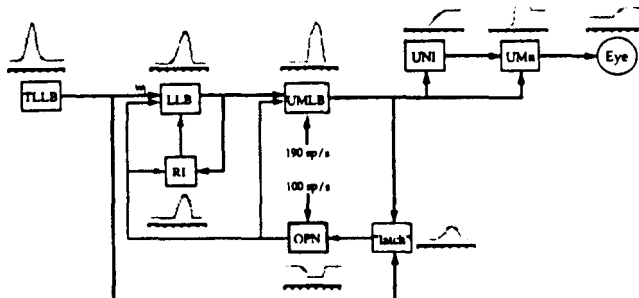

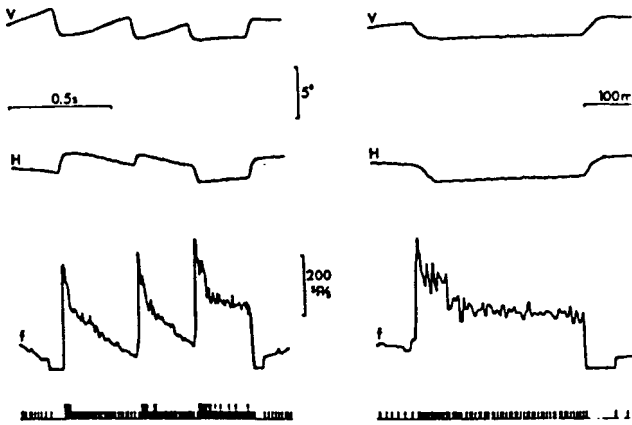

Figure 13

Intracellularly recorded discharge pattern of a primate superior oblique motoneuron at fast (left) and slow (right) sweep speeds, respectively. Trace lay out and abbreviations as in Fig. 7.

the firing rate of the motoneuron rises to a high value (a burst) for all saccades in its pulling direction (downward in the case of the superior oblique primate motoneuron of Figure 13) and then settles to a new level (which is proportional to the new position of the eyes in the orbit). This is precisely the waveform of the UMn element predicted by the model of Figure 12. Actually, the same is true of the activation functions of all elements of the model; they all replicate the discharge patterns that the neurons they correspond to display in an alert behaving primate.

Besides accounting for known neuronal discharge patterns, the output of a successful computational model of some piece of the brain should fit known psychophysics. How does the model of Figure 12 fare in this regard? Figure 14a illustrates the relationship between the size (ΔE) and duration (S_d) of saccades produced by the model of Figure 12. The two variables are related through the expression, $S_d = A\Delta E^k$ where A and k obtain values equal to 15.5 and 0.27, respectively, (Figure 14a, solid line). Note the close fit to monkey horizontal saccades ranging from 0.5° to 20° (stippled line). Except for the different slopes which are due to species differences, the

relationship ($V_{\max} = 56.6 + 42.7\Delta E$) between the size (ΔE) and the peak velocity (V_{\max}) of saccades produced by the model of Figure 12 (Figure 14b, open circles) is also similar to the main sequence curve of Figure 2. Moreover, a successful computational model should be able to replicate the results of electrical stimulation experiments such as those described in the beginning of this presentation. Figure 15 illustrates a staircase of saccades generated when the output element of the superior colliculus of the model of Figure 12 (the TLLB element) is clamped to a value of 800 spikes per second for about 250 ms. It is certainly reminiscent of staircases evoked in response to the electrical stimulation of an animal's superior colliculus. Finally, as already pointed out, parameters of neuronal discharge often encode kinematic or dynamic variables of movements. This is hardly surprising, given the fact that neurons cause behavior. With a lot of effort and some statistics, several relationships of this sort have been established. Due to space limitations I will not discuss the ability of computational models of the saccadic system to replicate higher order statistical relationships between parameters of neuronal discharge and saccade metrics. Interested readers are encouraged to consult the

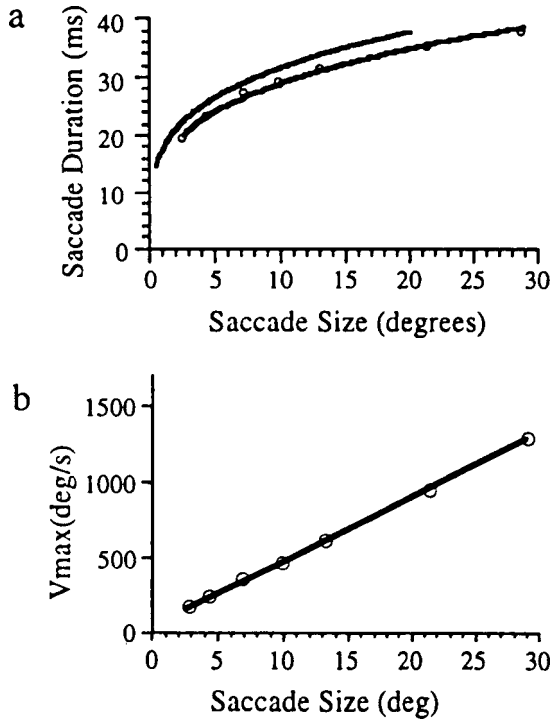

Figure 14

a. Plot of size versus duration of simulated saccades (reproduced from Moschovakis, A. K. Neural network simulations of the primate oculomotor system. I. The vertical saccadic burst generator. *Biological Cybernetics*, 70, 291-302, 1994, with permission). The thick solid line is the best fit to data produced by the MSH model (open circles). The stippled line, is the best fit to monkey horizontal saccades and is described by the expression $S_d = 17.7\Delta E^{0.25}$. b. Plot of saccade size versus peak velocity of saccades (V_{max}). The solid line is a linear fit to data produced by the MSH model (open circles).

original literature (e.g., Scudder, 1988; Moschovakis, 1994; Moschovakis & Highstein, 1994).

I hope I have convinced you that neuroscience is solidly advancing on a broad front. Detailed knowledge is being amassed on the leech and the owl, the locust and the monkey, the frog and the human, etc. It concerns processes such as vision, audition, smell, equilibrium, oculomotricity, head movements, reaching (with an arm), locomotion, etc. All this

evidence is incorporated into computational models of neural networks which replicate psychophysical laws, patterns of neuronal discharge, higher order statistical relationships between cell activity and behavioral variables as well as the results of lesion and stimulation experiments. Discrepancies between model and reality fuel additional research which generates new data in a spiralling scientific enterprise whose aim is to understand the brain and the way it creates the mind. You might object (together

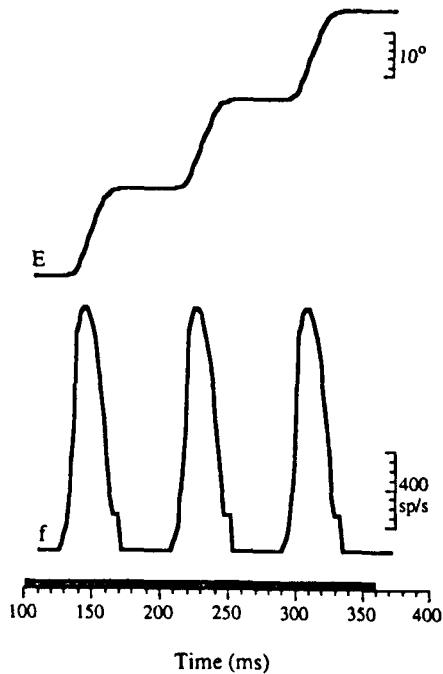

Figure 15

Simulated activation of the TLLB element of the MSH model for a period of about 250 ms (indicated by the bar on top of the time scale), to demonstrate network generation of saccadic staircase (reproduced from Moschovakis, A. K. Neural network simulations of the primate oculomotor system. I. The vertical saccadic burst generator. *Biological Cybernetics*, 70, 291-302, 1994, with permission).

with Mika Fatourou) that all this progress concerns observable phenomena and that the prospects of grounding the mind onto the brain diminish as one begins to deal with hidden, private, personal aspects of our mental lives. I consider this argument too pessimistic. There are several examples which demonstrate that it is possible to construct viable scientific theories about non-observable mental events. There is nothing public about the fact that gray rings appear reddish when they surround a green disk and greenish when they surround a red disk (an experience whose neurophysiological underpinnings are now understood). Other examples that come to mind are the classical

experiments of color matching and Purkinje images, as well as more recent ones that deal with attention and visual illusions. Our success so far in dealing with these issues is due to the fact that hidden things (experiences) are made visible thanks to the scientific ingenuity that endows subjects with the means to report on their experiences. Although many of these experiments are hard to do and interpret (thus rendering the whole enterprise very time consuming), I do not see why some mental phenomena would in principle be unreportable or that our ingenuity will dry out.

At the end of the road, I suspect that we will manage to reduce psychology to neuroscience.

Does this make neuroscience a threat to psychology? I do not think so, and to show why I must first explain what it is that intertheoretic reductions entail. Here I will pursue Hooker's line of argument (Hooker, 1981a, b, c). According to it, reduction is a special relationship that holds between two theories that live at two different levels, a high level and a lower level. Reduction occurs when statements, laws, concepts, etc. of the higher level theory can be predicted on the basis of statements, laws, concepts, etc. of the lower level theory (plus some boundary conditions that are called bridging statements). It is theories that are reduced, mind you, not statements. Intertheoretic reductions are rightly celebrated as important because they offer conceptual simplification and explanatory unification. However, whenever reduction is attempted, things can go right or they can go wrong. Some reductions are successful, in which case we talk of retention (of the high level theory). Here, it is all of the high level theory that is reduced lock, stock and barrel. A good example of this is the reduction of optics to electromagnetism; the whole corpus of optics was reduced to electromagnetism. Other reductions fail, in which case we talk of elimination (of the high level theory); the high level theory goes to the waste-basket, and nothing is left of it except for a few traces incorporated in the reducing theory. Consider what it is that is nowadays left of the theory of phlogiston in present day chemistry as regards burning, oxides, etc. To get back to the issue in hand, and considering the retention-elimination spectrum of the reduction continuum, I would bet that a lot of psychology (e.g., psychophysical laws) is (or will be) solid enough to be reduced to neuroscience. Instead of menacing, the prospect of a reduction of psychology to neuroscience should please psychologists as it implies that a lot of their work will endure the test of time.

This much covers the reduction of theories to other theories (epistemological reduction). What about the reduction of things to other things (ontological reduction)? In other words, let us ask (together with Giannis Kugiumutzakis) what

happens to things when their properties are explained in terms of laws, properties, etc. of lower level things. Contrary to arguments put forth by John Searle (1995), higher level things are not eliminated. For example, Carnot's cycle and our theories of how internal combustion engines work do not eliminate cars. What is eliminated is notions such as «a little green devil is lodged in the cylinders, moves the pistons and makes the wheels go round». Ontological reductions are met with skepticism for a more informative reason. It has been argued, that we could know everything that can be known about lower level things (take for example the atoms of oxygen and hydrogen) without being able to explain the properties of a higher level thing (water in our example). There is nothing mysterious about our inability to do so; it is due to the fact that we have artificially left out certain properties and one whole science. The properties in question have to do with the way parts interact to form a whole. In general, these need not be trivial and should be studied in their own terms. The science in question goes by the name «control systems theory». To see how this discipline works, consider two clocks with different periodicities. They keep time, but they keep a different time. One goes fast, the other goes slow. When both clocks are placed on the same wall the phenomenon of entrainment ensues. The two clocks go together but they do not go either with the period of the one or the period of the other. Control systems theory is about the many, many examples of this sort. Whenever two (or more) things are put together and they interact to form a system, something new emerges. Engineers often refer to these emergent things as virtual things. They do not exist, they are virtual. It's not the one clock, it's not the other clock, it's a virtual clock. Instead of admissions of defeat which take the form «I see a strange periodicity, but God only knows where it comes from», it is possible to explain such emergent properties completely provided that one obtains information about the properties of the parts (this is equivalent to the engineering terms «transfer function» and «input/output

relation»), about how they interact to make a whole (this is the «block diagram» of engineers), and some algebra (e.g., difference and differential equations, Laplace transforms, linear algebra, etc.). To get back to the possibility of an ontological reduction of mental events to brain states, I would predict that this will come to pass, thus adopting the position that bears the name «identity theory». I can understand why some people find this position hard to accept. The reason is that to get from the brain to the mind you need to deal with several levels of emergent properties. Many, many different channels get incorporated into the membranes of neurons. Their kinetics, their time and voltage dependence and their complex geometric arrangement gives rise to emergent phenomena (i.e., phenomena that live in a different world from the world of channel properties) such as the action potential. Thanks in part to action potentials, nerve cells are connected to other nerve cells in complex arrangements of interconnections which again give rise to emergent phenomena such as lateral inhibition. Networks of nerve cells interact with other networks of nerve cells to form larger cell assemblies such as patches in primary visual cortex which again display emergent properties (such as cepstral filtering to obtain disparity information and hence depth) when compared with their constituent networks, and so on. It is the fact that it involves so many different levels of organization the one built on top of another, so many reductive ontological steps the one coming on the heels of the other, that is unique to the brain and makes ontological reduction of the mind to it so difficult to accept.

It is normal to ask (together with Thanasis Tzavaras) whether ontological reduction of the mind to the brain assumes a deterministic mental life and whether this poses a threat to our most human characteristics, our notion of free-will, our subjective individuality, etc.? For the sake of argument, let us assume that we have managed to reduce psychology to neuroscience, neuroscience to biology, biology to chemistry and so on all the way down to physics. Let us further assume that the physical world is causally

closed in the Hamiltonian sense (i.e., given knowledge of the present position of all particles and their velocity we can predict their future positions and velocities for all time). Doesn't this imply that our mental life is also predetermined? In broad terms this is correct and I believe this is precisely the reason why present day dualists (e.g., Chalmers, 1996) are forced to occupy an epiphenomenalist position regarding the mind-body problem. Having said this, I believe that far from being undermined by determinism, the notion of free-will is inconceivable in a non-deterministic universe (this position goes by the name «compatibilism» and has been elaborated among others by Squires (1990)). To see why consider how you would feel if after wishing to move your hand the said hand sometimes moved and sometimes did not move. Our reluctance to come to terms with compatibilism is due to our unwillingness and/or our inability to keep track of all the relevant data about the world. Think of a merchantman that leaves Lisbon in the middle of the previous century, and which after many changes of direction (sail boats are notorious for their reliance on the direction of the wind), enters the harbor of New York, only to leave soon thereafter for Guam and thence for the cape of Good Hope, etc. Further consider that the merchantman is tracked by a Martian spaceship on a visit to earth. In the absence of additional data, the Martian would no doubt conclude that the journey is non-deterministic (with the possible exception of the capricious influence of winds and currents). However, were the obligations of the ship's captain towards the company that hired him, the obligations of the company towards investors and the price of commodities in different places of the planet taken into consideration, all indeterminacy vanishes.

Finally, far from posing a threat to subjective individuality, ontological reduction of the mind to the brain does justice to it. In part this is due to the fact that the brain may turn out to be a chaotic system, i.e., an entirely deterministic one that is nevertheless extremely sensitive to initial conditions. Such systems are characterized by the fact that small differences (or mistakes in

estimating) in initial conditions lead to wildly divergent trajectories. Furthermore, there is no doubt that all brains in general, and the human brain in particular, are exceedingly complex. They are made up of many cells (current estimates for the human brain go up to ten billion) and these are connected in complex ways (it is thought that each neuron talks to another 1000 neurons), which raises the total number of connections to 10^{15} (100 trillion). Assuming that the strength of each one of these connections varies over a ten-fold range (with weak ones taking the value of 1 and strong ones the value of 10), the number of possible states that the system can find itself in (i.e., the number of possible permutations) is $10^{100,000,000,000,000}$. To see how big this number is, compare it to 10^{87} , which is the estimated number of particles in the whole universe (a comparison often made by Paul Churchland 1995). No doubt, any mind reduced to a brain of such complexity leaves a lot of leeway for individuality.

REFERENCES

- Blasdel, G. G. (1992). Orientation selectivity, preference and continuity in monkey striate cortex. *Journal of Neuroscience*, 12, 3139-3161.
- Buettner-Ennever, J. A., & Henn, V. (1976). An autoradiographic study of the pathways from the pontine reticular formation involved in horizontal eye movements. *Brain Research*, 108, 155-164.
- Carpenter, M. B., & McMasters, R. E. (1963). Disturbances of conjugate horizontal eye movements in the monkey. II. Physiological effects and anatomical degeneration resulting from lesions in the medial longitudinal fasciculus. *Archives of Neurology (Chicago)*, 8, 347-368.
- Carpenter, M. B., McMasters, R. E., & Hanna, G. R. (1963). Disturbances of conjugate horizontal eye movements in the monkey. I. Physiological effects and anatomical degeneration from lesions of the abducens nucleus and nerve. *Archives of Neurology (Chicago)*, 8, 231-247.
- Churchland, P. M. (1996). *The conscious mind. In search of a fundamental theory*. Oxford: Oxford University Press.
- Churchland, P. M. (1995). *The engine of reason, the seat of the soul*. Cambridge, MA: MIT Press.
- Dememes, D., & Raymond, J. (1982). Radioautographic identification of 3H-glutamic acid labeled nerve endings in the cat oculomotor nucleus. *Brain Research*, 231, 433-437.
- Escudero, M., de la Cruz, R. R., & Delgado-Garcia, J. M. (1992). A physiological study of vestibular and prepositus hypoglossi neurones projecting to the abducens nucleus in the alert cat. *Journal of Physiology (London)*, 458, 539-560.
- Gacek, R. R. (1979). Location of abducens afferent neurons in the cat. *Experimental Neurology*, 64, 342-353.
- Getting, P. A. (1983). Mechanisms of pattern generation underlying swimming in *Tritonia*. II. Network reconstruction. *Journal of Neurophysiology*, 49, 1017-1035.
- Getting, P. A. (1989). Emerging principles governing the operation of neural networks. *Annual Review of Neuroscience*, 12, 185-204.
- Getting, P. A., & Degin, M. S. (1985). Mechanisms of pattern generation underlying swimming in *Tritonia*. IV. Gating of central pattern generator. *Journal of Neurophysiology*, 53, 466-480.
- Goebel, H. H., Komatsuzaki, A., Bender, M. B., & Cohen, B. (1971). Lesions of the pontine tegmentum and conjugate gaze paralysis. *Archives of Neurology (Chicago)*, 24, 431-440.
- Grantyn, A. A., Dalezios, Y., Kitama, T., & Moschovakis, A. K. (1996). Neuronal mechanisms of two-dimensional orienting movements in the cat. I. A quantitative study of saccades and slow drifts produced in response to the electrical stimulation of the superior colliculus. *Brain Research Bulletin*, 41, 65-82.
- Grantyn, R., Baker, R., & Grantyn, A. (1980). Morphological and physiological

- identification of excitatory pontine reticular neurons projecting to the cat abducens nucleus and spinal cord. *Brain Research*, 198, 221-228.
- Graybiel, A., & Hartweg, E. A. (1974). Some afferent connections of the oculomotor complex in the cat: An experimental study with tracer techniques. *Brain Research*, 81, 543-551.
- Graybiel, A. M. (1977). Direct and indirect preculomotor pathways of the brainstem: An autoradiographic study of the pontine reticular formation in the cat. *Journal of Comparative Neurology*, 175, 37-78.
- Highstein, S. M., & Baker, R. (1978). Excitatory synaptic terminations of abducens internuclear neurons on medial rectus motoneurons: relationship to syndrome of internuclear ophthalmoplegia. *Journal of Neurophysiology*, 41, 1647-1661.
- Highstein, S. M., Karabelas, A., Baker, R., & McCrea, R. A. (1982). Comparison of the morphology of physiologically identified abducens motor and internuclear neurons in the cat: A light microscopic study employing the intracellular injection of horseradish peroxidase. *Journal of Comparative Neurology*, 208, 369-381.
- Highstein, S. M., Maekawa, K., Steinacker, A., & Cohen, B. (1976). Synaptic input from the pontine reticular nuclei to abducens motoneurons and internuclear neurons in the cat. *Brain Research*, 112, 162-167.
- Hikosaka, O., Igusa, Y., & Imai, H. (1980). Inhibitory connections of nystagmus-related reticular burst neurons with neurons in the abducens, prepositus hypoglossi and vestibular nuclei in the cat. *Experimental Brain Research*, 39, 301-311.
- Hikosaka, O., Igusa, Y., Nakao, S., & Shimazu, H. (1978). Direct inhibitory synaptic linkage of pontomedullary reticular burst neurons with abducens motoneurons in the cat. *Experimental Brain Research*, 33, 337-352.
- Hikosaka, O., & Kawakami, T. (1977). Inhibitory reticular neurons related to the quick phase of vestibular nystagmus - their location and projection. *Experimental Brain Research*, 27, 377-396.
- Hooker, C. A. (1981a). Towards a general theory of reduction. Part I: Historical and scientific setting. *Dialogue*, 20, 38-59.
- Hooker, C. A. (1981b). Towards a general theory of reduction. Part II: Identity in reduction. *Dialogue*, 20, 201-236.
- Hooker, C. A. (1981c). Towards a general theory of reduction. Part III: Cross-categorical reduction. *Dialogue*, 20, 496-529.
- Igusa, Y., Sasaki, S., & Shimazu, H. (1980). Excitatory premotor burst neurons in the cat pontine reticular formation related to the quick phase of vestibular nystagmus. *Brain Research*, 182, 451-456.
- Langer, T., Kaneko, C. R. S., Scudder, C. A., & Fuchs, A. F. (1986). Afferents to the abducens nucleus in the monkey and cat. *Journal of Comparative Neurology*, 245, 379-400.
- Langer, T. P., & Kaneko, C. R. S. (1983). Efferent projections of the cat oculomotor reticular omnipause neuron region: An autoradiographic study. *Journal of Comparative Neurology*, 217, 288-306.
- Maciewicz, R. J., Eagen, K., Kaneko, C. R. S., & Highstein, S. M. (1977). Vestibular and medullary brain stem afferents to the abducens nucleus in the cat. *Brain Research*, 123, 229-240.
- Magnin, M., Courjon, J. H., & Flandrin, J. M. (1983). Possible visual pathways to the cat vestibular nuclei involving the nucleus prepositus hypoglossi. *Experimental Brain Research*, 51, 298-303.
- McCrea, R. A., & Baker, R. (1985). Anatomical connections of the nucleus prepositus of the cat. *Journal of Comparative Neurology*, 237, 377-407.
- McCrea, R. A., Strassman, A., & Highstein, S. M. (1986). Morphology and physiology of abducens motoneurons and internuclear neurons intracellularly injected with horseradish peroxidase in alert squirrel monkeys. *Journal of Comparative Neurology*, 243, 291-308.
- Moschovakis, A. K. (1994). Neural network

- simulations of the primate oculomotor system. I. The vertical saccadic burst generator. *Biological Cybernetics*, 70, 291-302.
- Moschovakis, A. K., & Highstein, S. M. (1994). The anatomy and physiology of primate neurons that control rapid eye movements. *Annual Review of Neurosciences*, 17, 465-488.
- Moschovakis, A. K., Scudder, C. A., & Highstein, S. M. (1991a). Structure of the primate burst generator. I. Medium-lead burst neurons with upward on-directions. *Journal of Neurophysiology*, 65, 203-217.
- Moschovakis, A. K., Sholomenko, G. N., & Burke, R. E. (1991b). Differential control of short latency cutaneous excitation in cat FDL motoneurons during fictive locomotion. *Experimental Brain Research*, 83, 489-501.
- Nakao, S., & Sasaki, S. (1980). Excitatory input from interneurons in the abducens nucleus to medial rectus motoneurons mediating conjugate horizontal nystagmus in the cat. *Experimental Brain Research*, 39, 283-293.
- Porter, J. D., Guthrie, B. L., & Sparks, D. L. (1985). Selective retrograde transneuronal transport of wheat germ agglutinin-conjugated horseradish peroxidase in the oculomotor system. *Experimental Brain Research*, 57, 411-416.
- Robinson, F. R., Straube, A., & Fuchs, A. F. (1993). Role of the caudal fastigial nucleus in saccade generation. II. Effects of muscimol inactivation. *Journal of Neurophysiology*, 70, 1741-1758.
- Sasaki, S., & Shimazu, H. (1981). Reticulovestibular organization participating in generation of horizontal fast eye movement. *Annals of the New York Academy of Sciences*, 374, 130-143.
- Schnyder, H., Reisine, H., Hepp, K., & Henn, V. (1985). Frontal eye field projection to the paramedian pontine reticular formation traced with wheat germ agglutinin in the monkey. *Brain Research*, 329, 151-160.
- Scudder, C. A. (1988). A new local feedback model of the saccadic burst generator. *Journal of Neurophysiology*, 59, 1455-1475.
- Scudder, C. A., Fuchs, A. F., & Langer, T. P. (1988). Characteristics and functional identification of saccadic inhibitory burst neurons in the alert monkey. *Journal of Neurophysiology*, 59, 1430-1454.
- Searle, J. R. (1995). *The rediscovery of the mind*. Cambridge, MA: MIT Press.
- Sirkin, D. W., & Feng, A. S. (1987). Autoradiographic study of descending pathways from the pontine reticular formation and the mesencephalic trigeminal nucleus in the rat. *Journal of Comparative Neurology*, 256, 483-493.
- Spencer, R. F., & Sterling, P. (1977). An electron microscope study of motoneurons and interneurons in the cat abducens nucleus identified by retrograde intraaxonal transport of horseradish peroxidase. *Journal of Comparative Neurology*, 176, 65-86.
- Squires, E. (1990). *Conscious mind in the physical world*. Bristol, U.K.: Adam Hilger.
- Stanton, G. B., & Greene, R. W. (1981). Brain stem afferents to the periabducens reticular formation (PARF) in the cat. An HRP study. *Experimental Brain Research*, 44, 419-426.
- Steiger, H.-J., & Buttner-Ennever, J. A. (1978). Relationship between motoneurons and internuclear neurons in the abducens nucleus: A double retrograde tracer study in the cat. *Brain Research*, 148, 181-188.
- Strassman, A., Highstein, S. M., & McCrea, R. A. (1986a). Anatomy and physiology of saccadic burst neurons in the alert squirrel monkey. I. Excitatory burst neurons. *Journal of Comparative Neurology*, 249, 337-357.
- Strassman, A., Highstein, S. M., & McCrea, R. A. (1986b). Anatomy and physiology of saccadic burst neurons in the alert squirrel monkey. II. Inhibitory burst neurons. *Journal of Comparative Neurology*, 249, 358-380.
- Yoshida, K., McCrea, R., Berthoz, A., & Vidal, P. (1982). Morphological and physiological characteristics of inhibitory burst neurons controlling horizontal rapid eye movements in the alert cat. *Journal of Neurophysiology*, 48, 761-784.